

Vse dimenzije so v milimetrih./All dimensions are in millimetres.

MM Ø	A	B Ø	CH	H *	H	H1 max	D Ø	EE	KK	NA	WF	VE	Y ± 5	PJ ** ± 5	ZJ **	V **
25	17	50	12	37	15	21	20	G 1/4	M 12x1.25	14	25	10	65	0	85	25
32	19	60	15	37	15	21	20	G 1/4	M 14x1.5	17	25	10	70	0	90	25
40	16	60	22	42	16	21	26	G 3/8	M 16x1.5	25	40	25	88	0	110	30
50	16	75	22	42	16	21	26	G 3/8	M 16x1.5	25	45	30	91	0	113	35
63	23	85	30	42	16	21	26	G 3/8	M 22x1.5	34	46	30	112	0	134	35
70	35	95	36	42	16	21	26	G 3/8	M 35x1.5	40	47	30	112	0	134	35
80	35	105	36	42	16	21	26	G 3/8	M 35x1.5	40	49	30	112	0	134	40
100	45	140	46	48	18	21	30	G 1/2	M 45x1.5	50	52	35	137	0	163	40
125	58	180	60	57	21	21	38	G 3/4	M 58x1.5	65	55	35	155	0	182	40
140	65	190	65	57	21	21	38	G 3/4	M 65x1.5	70	55	35	165	0	206	60

\* V priključek je možno namestiti blokirni ventil./Block valve can be mounted into the attachment.

\*\* Če je hod manjši od 50 mm, se vgradnji meri ZJ in PJ podaljšata za hod - 50mm.

\*\* Pri hodu nad 500 mm se vgradni meri ZJ in PJ podaljšata za dolžino V, zaradi dodatnega vodenja batnice.

\*\* In strokes shorter than 50 mm, mounting dimensions ZJ and PJ shall lengthen by the length of the stroke - 50mm.

\*\* In strokes exceeding 500 mm, mounting dimensions ZJ and PJ shall lengthen by the length V, due to additional piston rod guidance.

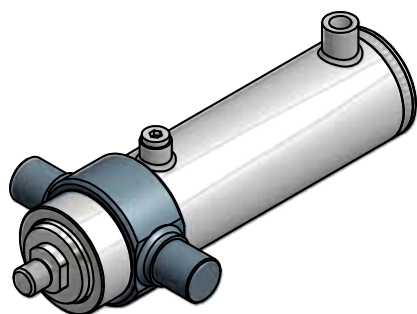

MM Ø	XV	BD	TD Ø f8	TM	TL	BL
25	37.5	25	20	90	16	70
32	40	30	25	105	20	80
40	55	30	25	105	20	80
50	62.5	35	30	120	25	100
63	63.5	35	30	120	25	110
70	69.5	45	40	135	32	125
80	71.5	45	40	135	32	135
100	84.5	65	60	195	50	180
125	97.5	85	80	240	60	235
140	97.5	85	80	240	60	235